

CK系列

NEW



特性

- 多种型号可选，适应各种场合
- 配置固定钢带和夹具，安装方便牢固
- 蓝线使用耐油PVC材料，防护等级高
- 统一标配柔软线材

应用

安全防护

磁性传感器应用场景案例：

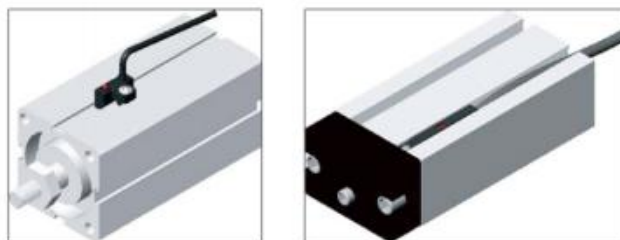

上海岭士智能技术有限公司

SHANGHAI LINESTAR SMART TECHNOLOGIES CO.LTD

上海市浦东新区浦东南路855号世界广场16A

021-6055 5575

www.linestartech.com

CK系列磁性传感器



项目	规格								
型号	CK-02R	CK-14R	CK-32R	CK-02N	CK-14N	CK-32N	CK-02P	CK-14P	CK-32P
	CK-03R	CK-AL14R	CK-39R	CK-03N	CK-AL14N	CK-39N	CK-03P	CK-AL14P	CK-39P
	CK-06R	CK-15R	CK-40R	CK-06N	CK-15N	CK-40N	CK-06P	CK-15P	CK-40P
	CK-07R	CK-16R	CK-72R	CK-07N	CK-16N	CK-72N	CK-07P	CK-16P	CK-72P
	CK-AL07R	CK-20R	CK-73R	CK-AL07N	CK-20N	CK-73N	CK-AL07P	CK-20P	CK-73P
	CK-11R	CK-21R	FMC01	CK-11N	CK-21N		CK-11P	CK-21P	
	CK-12R	CK-31R		CK-12N	CK-31N		CK-12P	CK-31P	
	CK-13R	CK-AL31R		CK-13N	CK-AL31N		CK-13P	CK-AL31P	
开闭逻辑	常开型			电子式无触点：常开型			电子式无触点：常开型		
感应开关形式	有接点磁簧管型			无触点晶体管NPN型			无触点晶体管PNP型		
使用电压范围	5~30VDC			5~30VDC			5~30VDC		
最大开关电流	≤100mA			≤200mA			≤200mA		
最大接电容量	≤3.5W			≤6W			≤6W		
内部消耗电流	无			≤14mA at 24V			≤11mA at 24V		
残留压降	≤2.5V at 10mA DC			≤2.5V at 10mA DC			≤2.5V at 10mA DC		
漏电流	无			≤0.01mA			≤0.01mA		
指示灯	红色LED			红色LED			绿色LED		
电缆线	Φ2.8, 2C/灰色耐油PVC			Φ2.8, 2C/灰色耐油PVC			Φ2.8, 2C/灰色耐油PVC		
最大开关切换频率	1000Hz			1000Hz			1000Hz		
适用温度范围	-10℃~70℃			-10℃~70℃			-10℃~70℃		
耐冲击	30G			50G			50G		
耐震动	9G			9G			9G		
耐震动	IP67			IP67			IP67		
耐震动	无			电源极性反向保护, 突波吸收保护			电源极性反向保护, 突波吸收保护		

型号规格

磁簧管/常开型

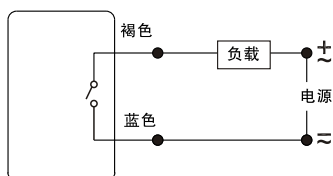

无触点NPN/常开型

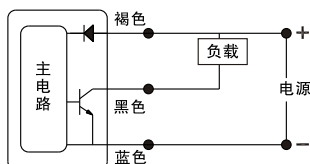



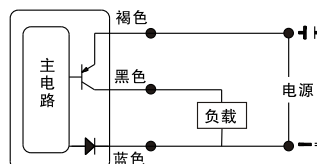







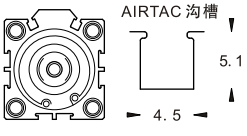

无触点PNP/常开型

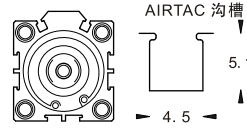

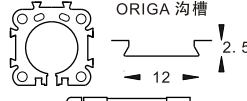

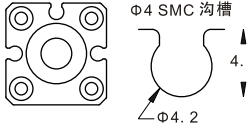

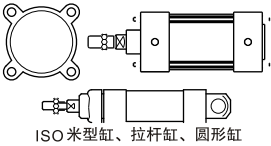

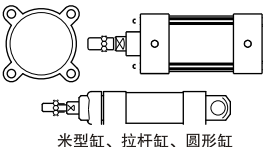



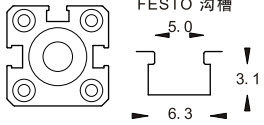

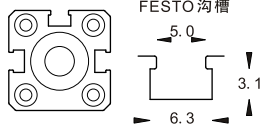
CK系列磁性传感器

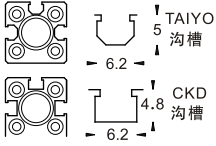
外观	型号	开关形式	使用电压	输出额定	适用汽缸
	CK-02R	磁簧管/常开型	5~120DC/AC	3.5W/100mA Max	
	CK-02N	无触点NPN/常开型	5~30VDC	6W/100mA Max	
	CK-02P	无触点PNP/常开型	5~30VDC	6W/100mA Max	
	CK-03R	磁簧管/常开型	5~240DC/AC	10W/100mA Max	
	CK-03N	无触点NPN/常开型	5~30VDC	6W/100mA Max	
	CK-03P	无触点PNP/常开型	5~30VDC	6W/100mA Max	
	CK-06R	磁簧管/常开型	5~240DC/AC	10W/100mA Max	
	CK-06N	无触点NPN/常开型	5~30VDC	6W/100mA Max	
	CK-06P	无触点PNP/常开型	5~30VDC	6W/100mA Max	
	CK-07R	磁簧管/常开型	5~240DC/AC	10W/100mA Max	
	CK-07N	无触点NPN/常开型	5~30VDC	6W/100mA Max	
	CK-07P	无触点PNP/常开型	5~30VDC	6W/100mA Max	
 金属外壳	CK-AL07R	磁簧管/常开型	5~240DC/AC	10W/100mA Max	
	CK-AL07N	无触点NPN/常开型	5~30VDC	6W/100mA Max	
	CK-AL07P	无触点PNP/常开型	5~30VDC	6W/100mA Max	
	CK-11R	磁簧管/常开型	5~240DC/AC	10W/100mA Max	
	CK-11N	无触点NPN/常开型	5~30VDC	6W/100mA Max	
	CK-11P	无触点PNP/常开型	5~30VDC	6W/100mA Max	
	CK-12R	磁簧管/常开型	5~240DC/AC	10W/100mA Max	
	CK-12N	无触点NPN/常开型	5~30VDC	6W/100mA Max	
	CK-12P	无触点PNP/常开型	5~30VDC	6W/100mA Max	

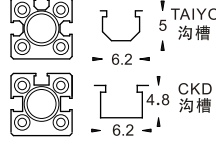
CK系列磁性传感器

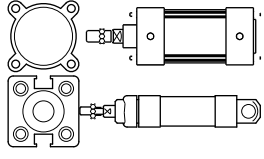
外观	型号	开关形式	使用电压	输出额定	适用汽缸
	CK-13R	磁簧管/常开型	5~240DC/AC	10W/100mA Max	 全缸径圆形缸
	CK-13N	无触点NPN/常开型	5~30VDC	6W/100mA Max	
	CK-13P	无触点PNP/常开型	5~30VDC	6W/100mA Max	
	CK-14R	磁簧管/常开型	5~240DC/AC	10W/100mA Max	 AIRTAC 沟槽 5.1 4.5
	CK-14N	无触点NPN/常开型	5~30VDC	6W/100mA Max	
	CK-14P	无触点PNP/常开型	5~30VDC	6W/100mA Max	
 金属外壳	CK-AL14R	磁簧管/常开型	5~240DC/AC	10W/100mA Max	 AIRTAC 沟槽 5.1 4.5
	CK-AL14N	无触点NPN/常开型	5~30VDC	6W/100mA Max	
	CK-AL14P	无触点PNP/常开型	5~30VDC	6W/100mA Max	
	CK-15R	磁簧管/常开型	5~240DC/AC	10W/100mA Max	 ORIGA 沟槽 2.5 12  Φ6 ~ Φ6 圆形汽缸
	CK-15N	无触点NPN/常开型	5~30VDC	6W/100mA Max	
	CK-15P	无触点PNP/常开型	5~30VDC	6W/100mA Max	
	CK-16R	磁簧管/常开型	5~240DC/AC	10W/100mA Max	 Φ4 SMC 沟槽 4.6 Φ4.2
	CK-16N	无触点NPN/常开型	5~30VDC	6W/100mA Max	
	CK-16P	无触点PNP/常开型	5~30VDC	6W/100mA Max	
	CK-20R	磁簧管/常开型	5~240DC/AC	10W/100mA Max	 ISO 米型缸、拉杆缸、圆形缸
	CK-20N	无触点NPN/常开型	5~30VDC	6W/100mA Max	
	CK-20P	无触点PNP/常开型	5~30VDC	6W/100mA Max	
	CK-21R	磁簧管/常开型	5~240DC/AC	10W/100mA Max	 米型缸、拉杆缸、圆形缸
	CK-21N	无触点NPN/常开型	5~30VDC	6W/100mA Max	
	CK-21P	无触点PNP/常开型	5~30VDC	6W/100mA Max	

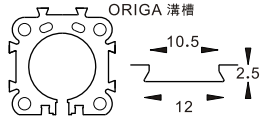
CK系列磁性传感器

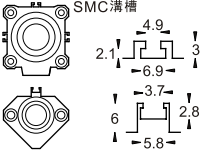
外观	型号	开关形式	使用电压	输出额定	适用汽缸
	CK-31R	磁簧管/常开型	5~240DC/AC	10W/100mA Max	 FESTO 沟槽 5.0 3.1 6.3
	CK-31N	无触点NPN/常开型	5~30VDC	6W/100mA Max	
	CK-31P	无触点PNP/常开型	5~30VDC	6W/100mA Max	
 金属外壳	CK-AL31R	磁簧管/常开型	5~240DC/AC	10W/100mA Max	 FESTO 沟槽 5.0 3.1 6.3
	CK-AL31N	无触点NPN/常开型	5~30VDC	6W/100mA Max	
	CK-AL31P	无触点PNP/常开型	5~30VDC	6W/100mA Max	
	CK-32R	磁簧管/常开型	5~240DC/AC	10W/100mA Max	 TAIYO 沟槽 5 6.2 4.8 CKD 沟槽 6.2
	CK-32N	无触点NPN/常开型	5~30VDC	6W/100mA Max	
	CK-32P	无触点PNP/常开型	5~30VDC	6W/100mA Max	
	CK-36R	磁簧管/常开型	5~240DC/AC	10W/100mA Max	 TAIYO 沟槽 5 6.2 4.8 CKD 沟槽 6.2
	CK-36N	无触点NPN/常开型	5~30VDC	6W/100mA Max	
	CK-36P	无触点PNP/常开型	5~30VDC	6W/100mA Max	
	CK-39R	磁簧管/常开型	5~240DC/AC	10W/100mA Max	
	CK-39N	无触点NPN/常开型	5~30VDC	6W/100mA Max	
	CK-39P	无触点PNP/常开型	5~30VDC	6W/100mA Max	
	CK-40R	磁簧管/常开型	5~240DC/AC	10W/100mA Max	 ORIGA 沟槽 10.5 2.5 12
	CK-40N	无触点NPN/常开型	5~30VDC	6W/100mA Max	
	CK-40P	无触点PNP/常开型	5~30VDC	6W/100mA Max	
	CK-72R	磁簧管/常开型	5~240DC/AC	10W/100mA Max	 SMC 沟槽 4.9 2.1 6.9 3 3.7 2.8 5.8 6
	CK-72N	无触点NPN/常开型	5~30VDC	6W/100mA Max	
	CK-72P	无触点PNP/常开型	5~30VDC	6W/100mA Max	

CK系列磁性传感器

外观	型号	开关形式	使用电压	输出额定	适用汽缸
	CK-73R	磁簧管/常开型	5~240DC/AC	10W/100mA Max	 <p>SMC 沟槽</p> <p>4.9 2.1 6.9 3 3.7 2.8 6 5.8</p>
	CK-73N	无触点NPN/常开型	5~30VDC	6W/100mA Max	
	CK-73P	无触点PNP/常开型	5~30VDC	6W/100mA Max	
 <p>门磁开关</p>	FMC01	磁簧管/常开型	5~240DC/AC	10W/100mA Max	 <p>28.5 15.3 4*6, 6 Ø2.5 2 2000</p>

CK-02R

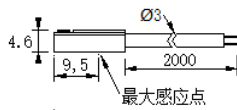

CK-02N/P

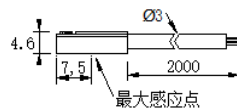

CK-02R/-M1 N/-M1 P/-M1

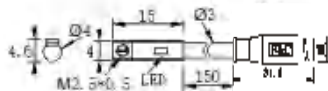

CK-03R

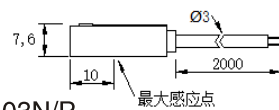

CK-03N/P

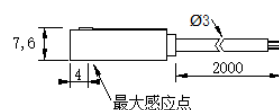

CK-03R/-M1 N/-M1 P/-M1

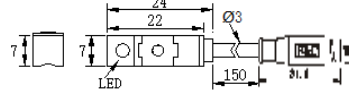

CK-06R

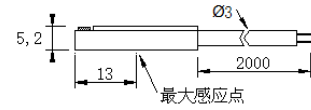

CK-06N/P

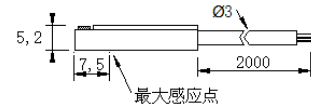

CK-06R/-M1 N/-M1 P/-M1

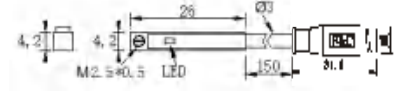

CK-07R

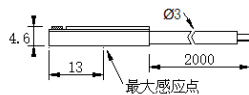

CK-07N/P

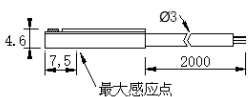

CK-07R/-M1 N/-M1 P/-M1

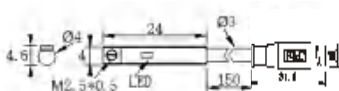

CK-AL07R

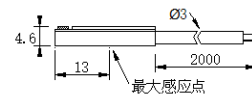

CK-AL07N/P

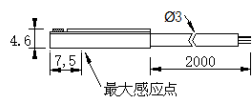

CK-AL07R/-M1 N/-M1 P/-M1

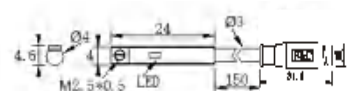

CK-11R

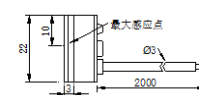

CK-11N/P

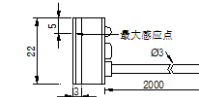

CK-11R/-M1 N/-M1 P/-M1



CK-12R

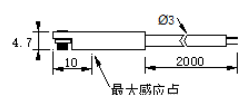

CK-12N

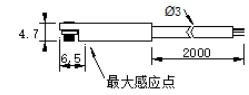

CK-12R/-M1 N/-M1 P/-M1



CK-13R

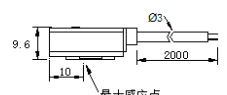

CK-13N

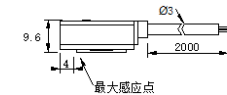

CK-13R/-M1 N/-M1 P/-M1

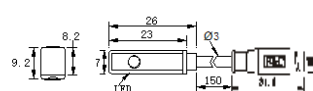

CK-14R

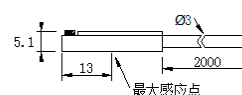

CK-14N

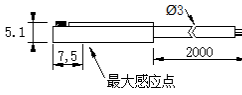

CK-14R/-M1 N/-M1 P/-M1

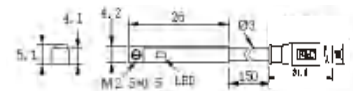

CK-AL14R

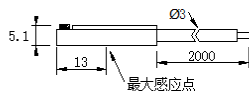

CK-AL14N/P

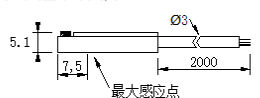

CK-AL14R/-M1 N/-M1 P/-M1

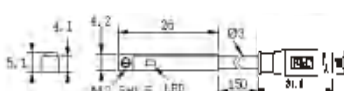

FD-15R/N/P

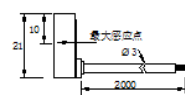

CK-15R/15D N/15D P/15D

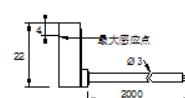

CK-15R/-M1 N/-M1 P/-M1D

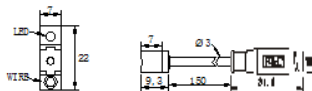

CK-16R

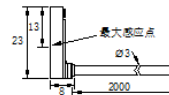

CK-16N

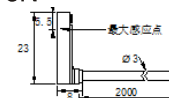

CK-16R/-M1 N/-M1 P/-M1

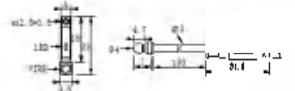

CK-20R

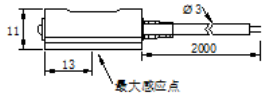

CK-20N/P

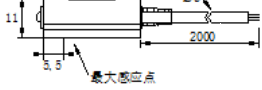

CK-20R/-M1 N/-M1 P/-M1

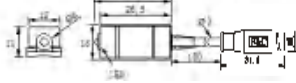

CK-21R

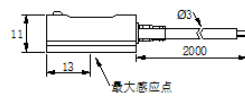

CK-21N/P

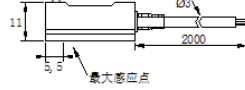

CK-21R/-M1 N/-M1 P/-M1

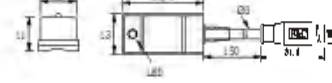

CK-31R

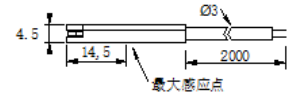

CK-31N/P

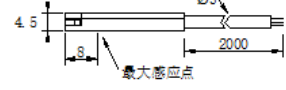

CK-31R/-M1 N/-M1 P/-M1

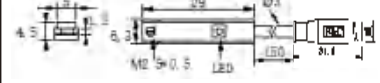

CK-AL31R

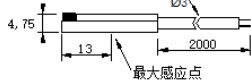

CK-AL31N/P

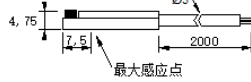

CK-AL31R/-M1 N/-M1 P/-M1

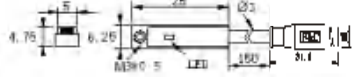

CK-32R

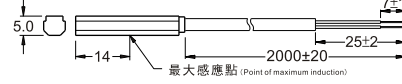

CK-32N/P

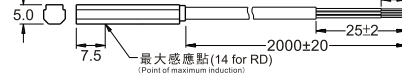

CK-32R/-M1 N/-M1 P/-M1

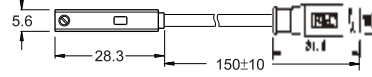

CK-36R

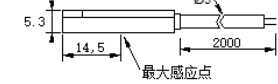

CK-36N/P

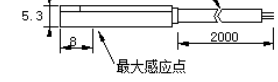

CK-36R/-M1 N/-M1 P/-M1

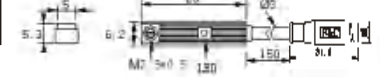

CK-39R

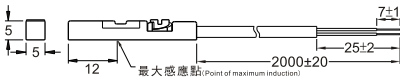

CK-39N

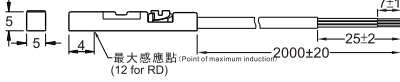

CK-39R/-M1 N/-M1 P/-M1

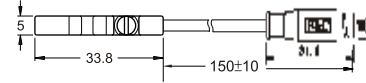

CK-40R

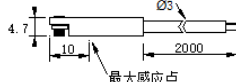

CK-40N

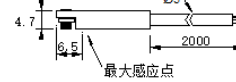

CK-40R/-M1 N/-M1 P/-M1

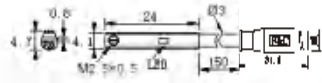

CK-72R

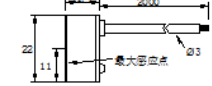

CK-72N

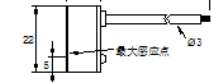

CK-72R/-M1 N/-M1 P/-M1



CK-73R

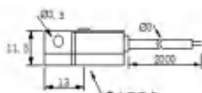

CK-73N/P

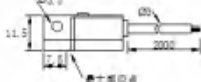

CK-73R/-M1 N/-M1 P/-M1

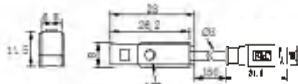

FMC01

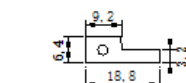
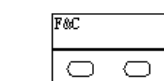
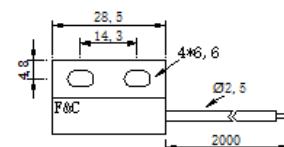

M8及M12航空接头
(M8 and M12 connectors Airlines)

两线式公接头
(Wire-type male connector)

三线式公接头
(Three-wire male connector)

M8 3M

褐色 (+) 1



M8 4M

褐色 (+) 1



M12 3M

蓝色 (-) 3



M12 4M

蓝色 (-) 3



一、固定钢带

适用于 $\phi 12\text{mm}$ 以上的圆形汽缸或拉杆汽缸
 PAB-1 适用于 $\phi 12\sim\phi 63$
 PAB-2 适用于 $\phi 12\sim\phi 125$

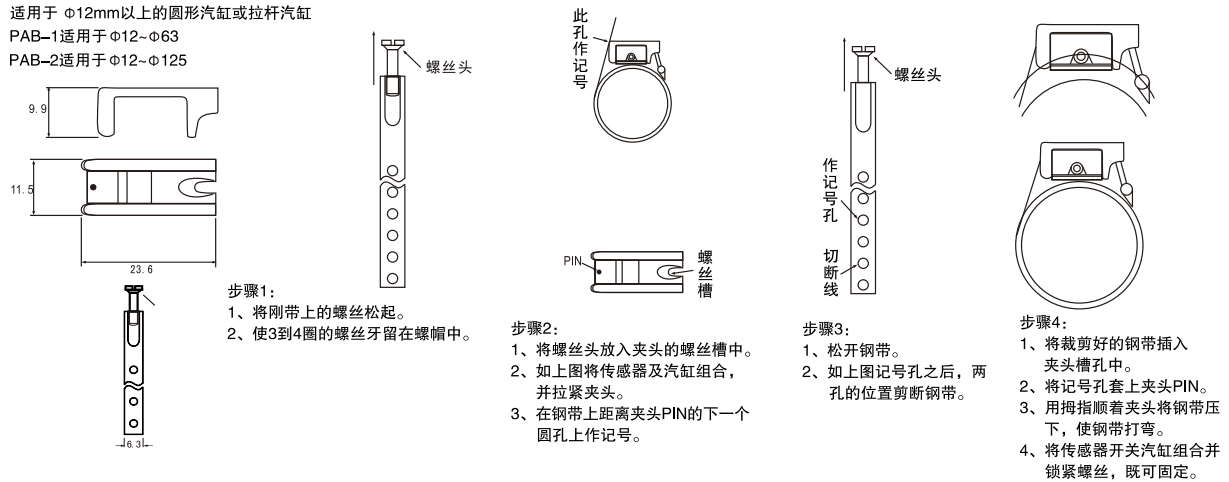

PBN固定钢带

专用与CK-20和CK-21系列磁感应开关
 PBN-1: 适用于 $\phi 6\sim\phi 63$ 圆形汽缸或拉杆汽缸。
 PBN-2: 适用于 $\phi 10\sim\phi 125$ 圆形汽缸或拉杆汽缸。

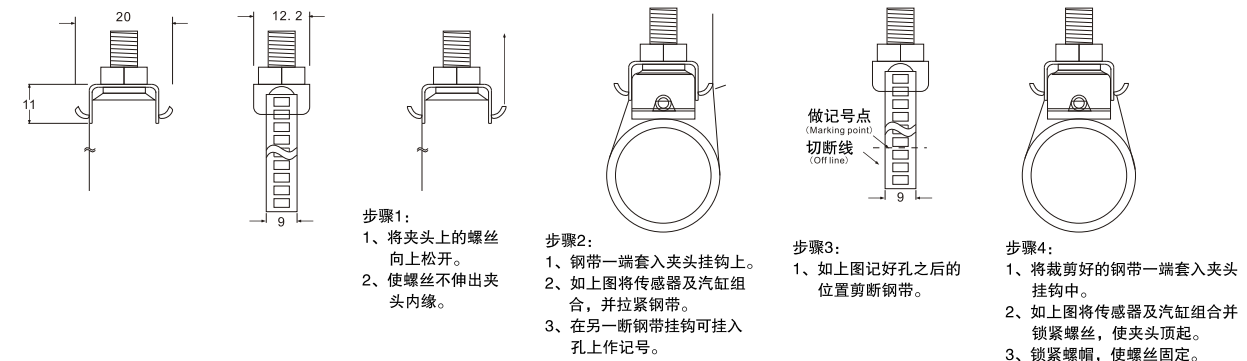

二、固定夹具

专用于固定CK-20和CK-21系列磁感应开关

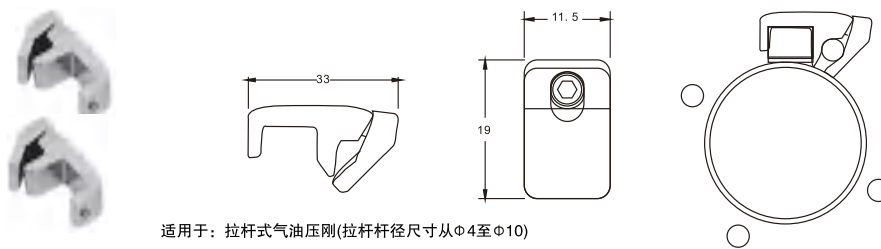

专用于固定CK-20和CK-21系列磁感应开关

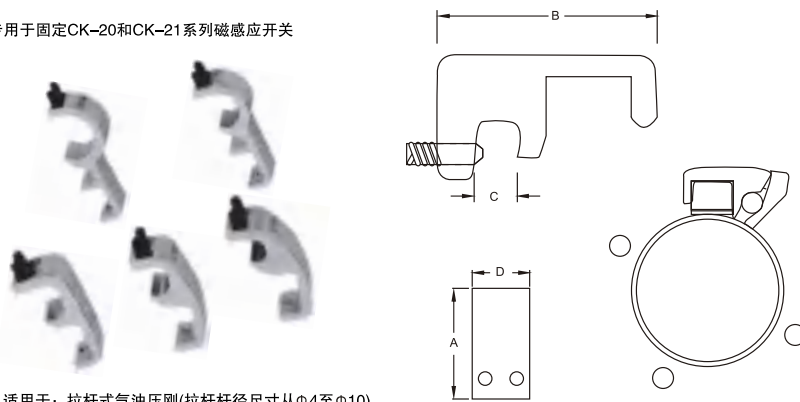

型号/尺寸	A	B	C	D
PM-6	14.0	32.3	8.3	11.5
PM-8	14.0	34.3	8.3	11.5
PM-10	15.5	35	10.3	11.5
PM-12	16.2	45	12.3	11.5
PM-16	18.2	52.3	16.5	11.5

适用于: $\phi 32$ 至 $\phi 100$ ISOprofile气压缸(米缸型)

